

The Crescendo 8MB is designed as a bass mid driver for use in two way ported enclosures. The smooth frequency response and roll off both on and off axis make this unit extremely suitable for systems where it is necessary to use the high frequency driver above 3kHz.

Built around a die cast chassis the unit features a 1.5 inch aluminium voice coil, paper cone and elastomer damped fabric surround and dome. It has an average sensitivity of 94dB and 140 Watt power handling. The 8MB is best used in ported enclosures of 12 to 25 litres.

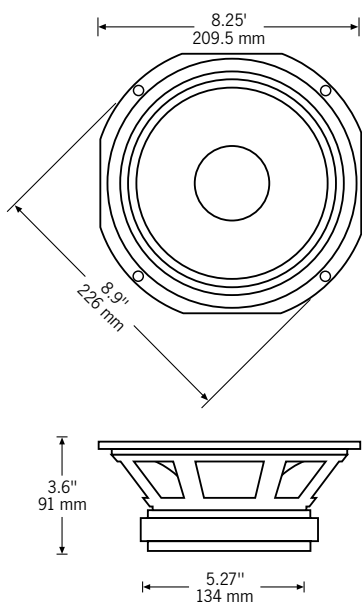
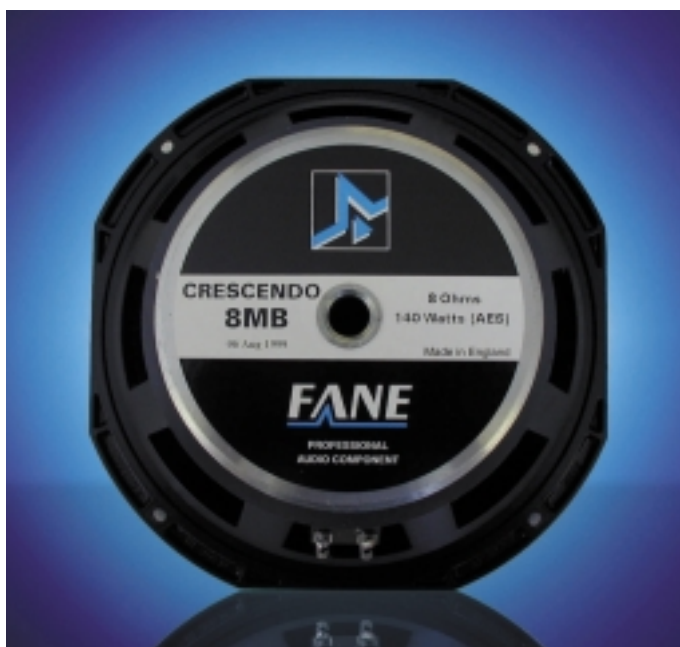

Mounting information

Overall Diameter	8.9 inch/226 mm
Width Across Flats	8.25 inch/209.5 mm
Flange Thickness	0.280 inch/7 mm
Baffle Hole Diameter, Front Mount	7.33 inch/186 mm
Gasket Supplied	Rear
Fixing Holes	4 x 0.218 inch diam on 8.41 PCD 4 x 5.5 mm diam on 213.5 PCD
Depth	3.62 inch/92 mm
Weight	7.0 lb/3.2 kg
Recommended Enclosure Volume	42-1 cu ft/12-28 litres
Volume Displaced by Driver	0.035 cu ft/1 litre
Shipping Weight	7.5 lb/3.4 kg
Packing Carton Dimensions	235 x 235 x 165 mm

Frequency response data

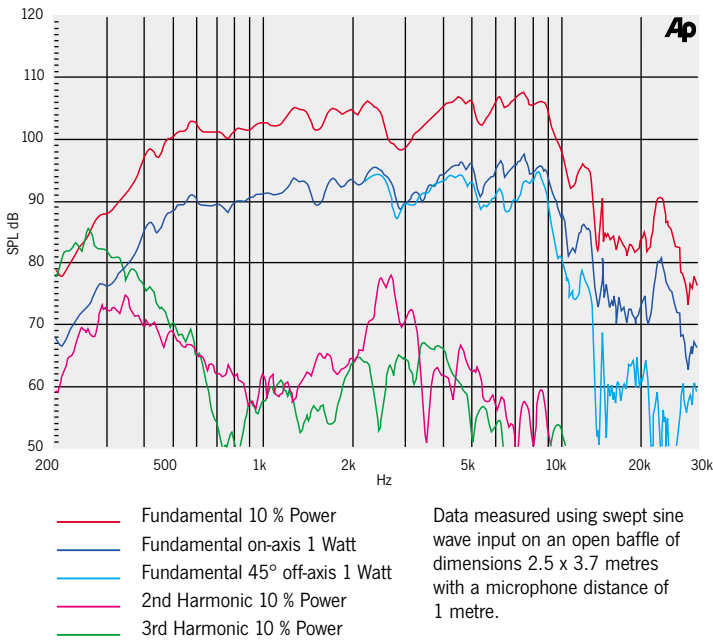

Impedance

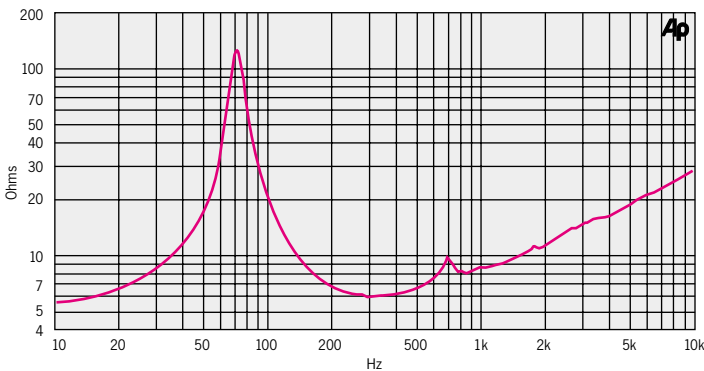

Computer predicted bass response

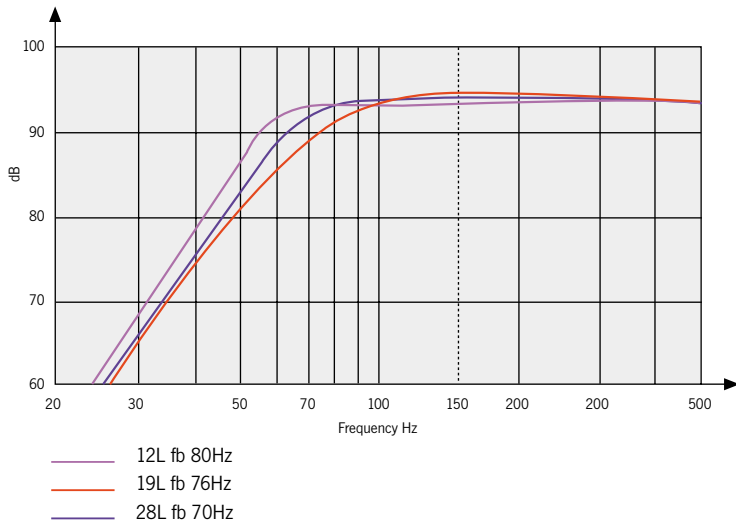

Electro mechanical specifications

Nominal Chassis Diameter	8 inch/200 mm
Impedance	8 Ω
Power Handling	140 (A.E.S.) ¹
Maximum Output Continuous/Peak	113/119 dB
Power Compression at Rated Power	3 dB
Usable Frequency Range (-6 dB)	50 Hz-4.5 kHz
Average Sensitivity (in above range) 1W/1m	94 dB
Resonance	70 Hz
Moving Mass inc. Air Load	21.5 grams
BL Product (Newtons/amp)	10.52
Minimum Impedance (Zmin)	6.2
Effective Piston Diameter	6.42 inch/163 mm
Flux Density	1.1 Tesla
Magnetic Gap Depth	0.236 inch/6 mm
Coil Winding Height	0.59 inch/15 mm
Voice Coil Length	36 feet/11 m
Magnet Weight	38 oz/1.1 kg
Maximum Cone Displacement	0.39 inch/10 mm
Peak Displacement Volume of Cone, Vd	.19 litres
Voice Coil Diameter	1.5 inch/38 mm

Construction materials

Coil Former	Fibreglass
Voice Coil Material	Aluminium
Magnet	Ferrite
Chassis	Die Cast Aluminium
Cone	Curvilinear Paper
Surround/Edge Termination	Polyvinyl Damped Double Half Roll Linen
Dust Dome	Polyvinyl Damped Linen
Connectors	Solder Tab Terminals
Polarity	Positive voltage at red terminal causes forward motion of cone

Thiele-Small parameters

Resonant Frequency fs	70 Hz
D.C Resistance Re	5.05
Qts	0.405
Qes	0.430
Qms	6.98
Mms (grams)	21.5
Cms (microns per Newton)	240
BL Product	10.54 Tesla metres
Vas	15.4 litres
Reference Efficiency ηo	1.19 %
Piston Area Sd	0.021 m ²
Xmax	4.5 mm

¹ A.E.S. power handling test. Pink noise bandpass filtered at 12 dB per octave with cutoff frequencies of 30 Hz and 300 Hz. Driver mounted in free air, test signal applied at rated power for two hours.